

# RoundTrack

RoundTrack systems  
**Transport great  
loads intelligently**





## RoundTrack: Transport systems from entry to ultra class

RoundTrack is the ideal transport system for intelligent transport of great loads. It allows even extremely heavy loads to be transported with the lowest possible energy input. The precise and reliable track guiding function is based on the Strothmann RoundTrack system. A broad selection of carts from low-cost aluminum carts to Automated Guided Vehicles for sophisticated applications offers great flexibility.

### Total simplicity

The RoundTrack system makes it possible to move even extremely heavy loads with ease: from individual components weighing tons to complete machines. Quick installation and system availability permit uncomplicated integration into the production workflow.

### Total safety

The guided system guarantees safe load transport. Flush installation and uncomplicated handling ensure optimum safety during product transport.

### Total efficiency

As a structural aid the RoundTrack system inherently promotes efficient transport processes. Thanks to the minimal energy input required for moving loads and because the system is practically maintenance- and wear-free, it quickly pays for itself.

# 200 t

Extreme strength:  
safe and reliable  
material transport  
of up to 200 t

# 5 t

Optimized ergonomics:  
up to 5 t can be  
pushed manually by  
one person





## RoundTrack: Highly precise and reliable track guiding

The Strothmann RoundTrack is the basis for the highly precise and reliable cart track guiding function. The wheels ensure minimal rolling resistance while reliably guiding the system. Even heavy objects weighing up to 5 tons can be moved by hand.

### Maintenance-free system

The round rails made of hardened, polished steel and the wheels made of ball bearing steel are designed for a long service life. The RoundTrack is flush with the building floor, making it possible to move across it with forklift trucks and platform floor trucks. Moreover, the lack of tripping hazards guarantees optimized safety at work. The clamping profile on both sides makes it easy to replace the aluminum profile in the event of damage.

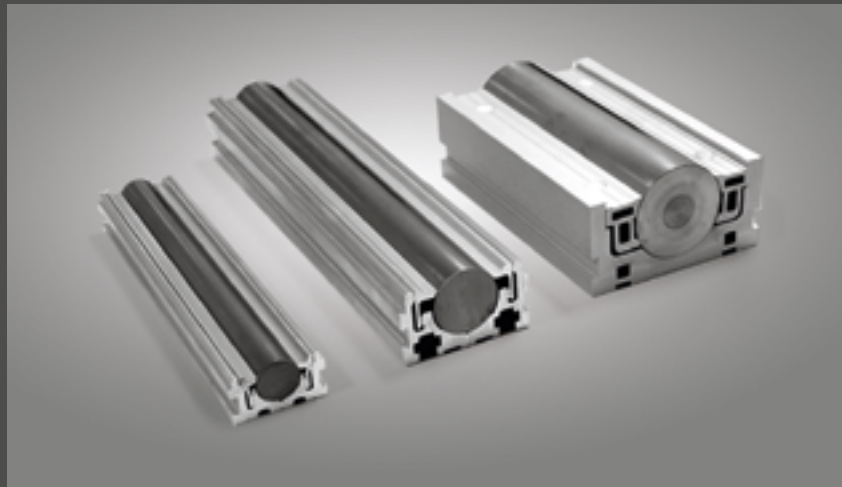

### RoundTracks for all load segments

RoundTracks with diameters of 25, 40, and 60 mm are available to accommodate different payloads per wheel. The RoundTrack RS60 has a nominal load-bearing capacity of 15 tons per wheel. Even a carriage with four duo cassettes can move 120 t.



RS25  
up to 40 t\*  
50 x 100 mm\*\*

RS40  
up to 80 t\*  
75 x 140 mm\*\*

RS60  
up to 200 t\*  
90 x 180 mm\*\*

\* max. payload capacity per cart

\*\* Installation channel size, height x width in mm

### RoundTrack installation in 4 steps.

Strothmann's cooperation partners around the world are available to install the RoundTrack. The track guiding system is integrated in the building floors in four steps. For further information, please refer to our installation conditions.

1.

Measuring  
and marking  
floor slots

2.

Cutting, chiseling  
and cleaning  
floor slots

3.

Positioning  
and aligning  
RoundTrack

4.

Grouting  
RoundTrack  
in the channel

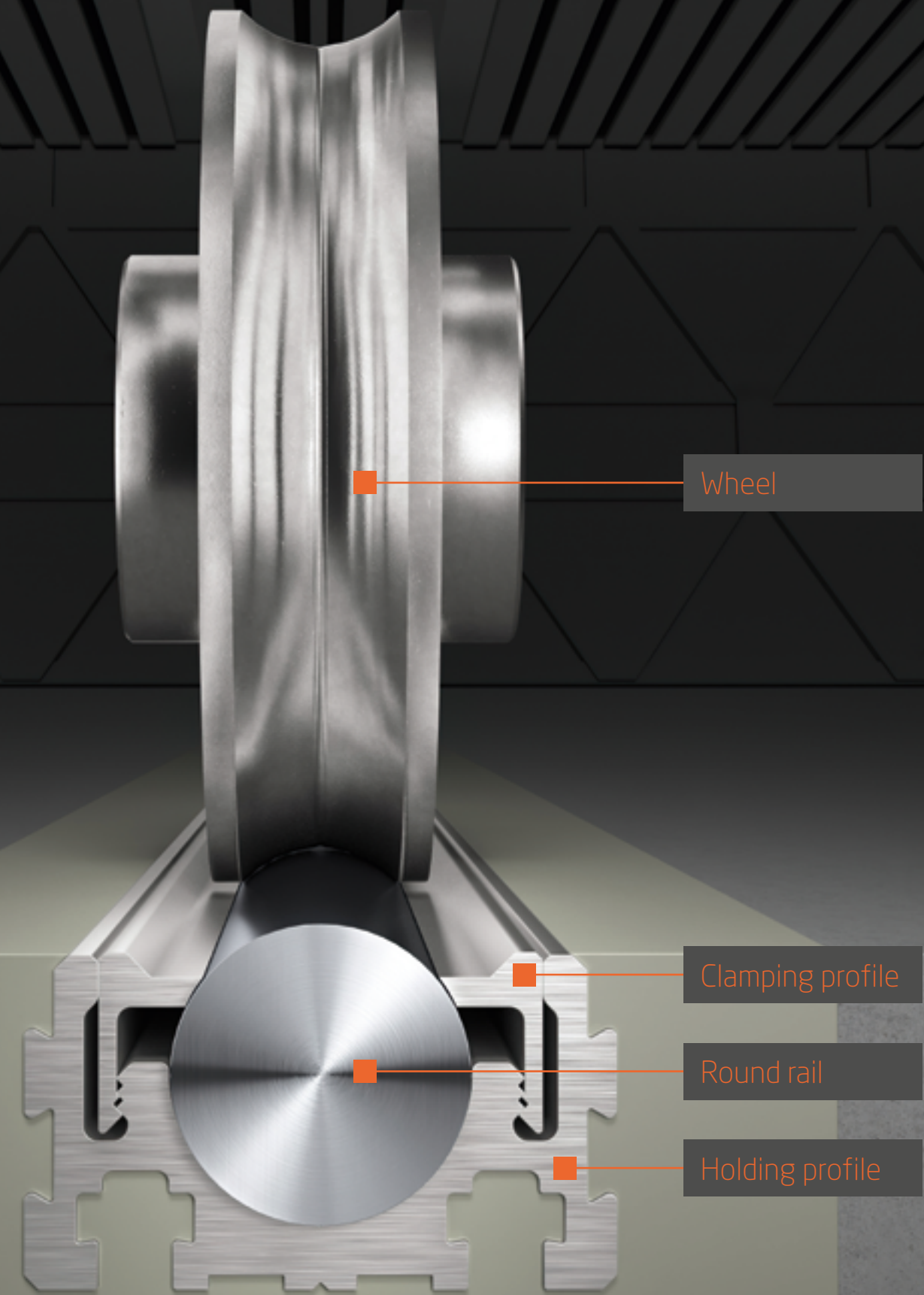



## RoundTrack: System advantages

The RoundTrack sets standards for efficient product and material flow of loads weighing up to 200 t. It is capable of transporting heavy components or even entire machines and systems. This means the RoundTrack system offers all the advantages of modern line assembly in entirely new dimensions.

### Flush with floor level

Tracks are protruding only a few millimeters above of the floor: no trip hazard, traversable, high cleanliness.

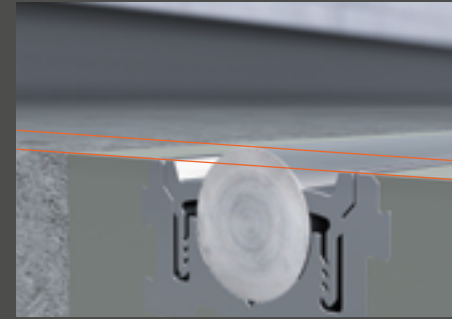

3 mm above ground level with RoundTrack 25

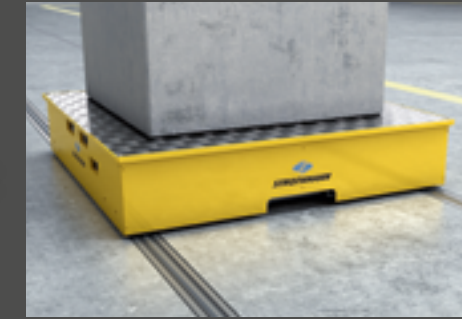

Height tolerance  $\pm 1$  mm over a 5 m track, tolerance of the track gauge,  $\pm 0.5$  mm



High energy efficiency due to extremely low rolling resistance



**5 t**

Optimized ergonomics:  
up to 5 t can be  
pushed manually by  
one person

  
**STROTHMANN**



## The RoundTrack advantage

Compared with other transport systems, the Strothmann solution offers numerous benefits: e.g. directional stability, energy efficiency, safety, quality and cost.



### Advantage over heavy-duty castors/Vulkollan wheels

The RoundTrack offers an impressive reduction of the rolling friction coefficient by a factor of >10 and therefore requires significantly less energy than the above-mentioned systems. Moreover, the RoundTrack wheel is highly resistant to environmental factors and foreign objects along its route. The compact design permits a relatively low cart height and the form closure integrated in the wheel profile allows for absorption of transverse forces and reliable track guiding. As an extra benefit, the RoundTrack steel wheels are 100 % recyclable, making them more sustainable than any other material.

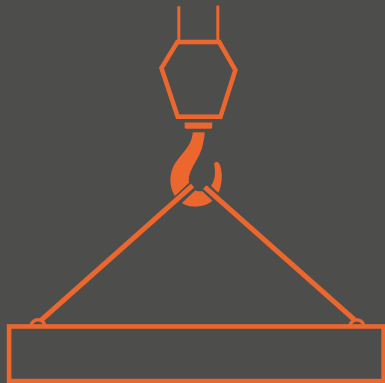

### Advantages over crane systems

The RoundTrack system is easy to implement in existing production workshops and does not require complicated workshop infrastructure. Floor-level transport ensures greater safety. The transport carriages in use are available immediately at all times and do not require additional auxiliary equipment. There are no recurring costs for special training courses or safety inspections of slinging means.

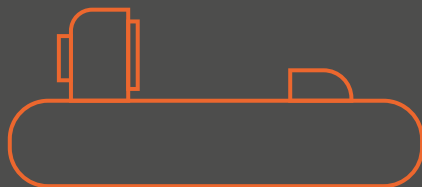

### Advantages over air cushion vehicles





Once again, the RoundTrack system has lower energy requirements. The RoundTrack does not require expensive preparation of a pneumatic system nor additional energy for lifting the load. The floor work required is also limited to installation of the RoundTrack, so no extensive floor preparation and maintenance is necessary.



### Advantage over alternative rail systems

Compared with other rail systems, the Strothmann RoundTrack offers exceptional benefits. This comparison is based on an assessment by TEG-S of the Fraunhofer Society.

1 = very good  
6 = unsatisfactory

	 Crane track	 Crane track with rubber filling	 Railway track	 Tram track	 Strothmann RoundTrack
Protection against dirt	2	1	2	5	2
Ease of cleaning	4	1	4	5	2
Avoidance of edge loads	5	5	4	4	1
Track precision	4	4	5	5	1
Rolling resistance	4	6	3	4	1
Accident prevention	6	1	6	4	1
Reduction in wear	3	6	4	4	1
Load-bearing capacity	2	2	3	3	2
Replaceability	6	6	5	6	1
<b>Average</b>	<b>4</b>	<b>3.6</b>	<b>4</b>	<b>4.4</b>	<b>1.6</b>



## The Strothmann transport cart fleet

Strothmann transport systems are designed for flexible use in a variety of industries: from standard to customized carts. The driverless transport system uTrack is a first-class solution for complex applications. All transport systems permit flexible expansion.

### Powered transport systems

#### PulseTrack

Pulse conveyor plus carts

#### ServoTrack

Transport carts

### Automated Guided Vehicles

#### uTrack

Transport carts

### Manual transport systems

#### LeanTrack

Standard carts

#### CustomTrack

Customised carts

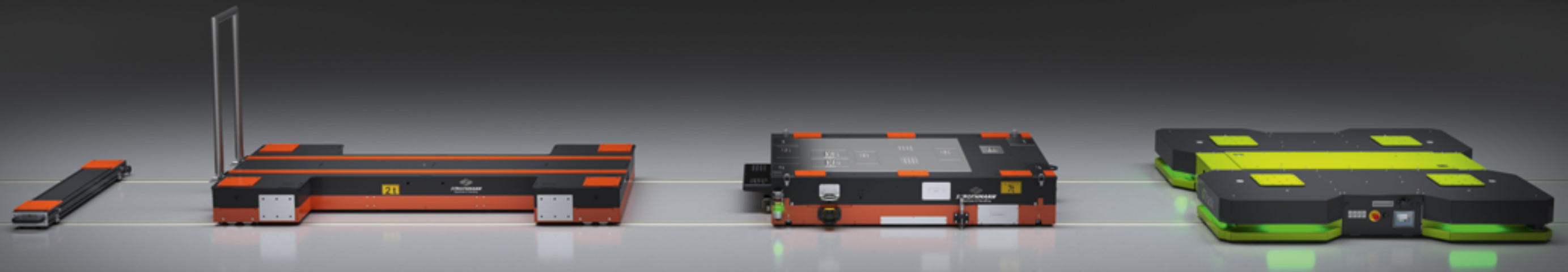



# LeanTrack

## The entry-level product of transport systems

The standard aluminum or steel cart is suitable for easy and quick implementation of many applications. One person can move up to 5 t. You benefit from quick delivery.

### LeanTrack: the light-weight aluminum cart

For simple applications even two aluminum carts are enough to move loads of up to 16 t. Returning the cart at the end of the transport route is also simple: LeanTrack can be rolled back to the starting point on wheels like a trolley suitcase. Yet another highlight is the simple configuration and ordering process for the system via the web shop.



### LeanTrack: the robust steel variant

LeanTrack steel carts are designed for greater loads: one cart can move up to 36 t. Moreover, the carts have a larger load accommodation area thanks to their sturdy welded structure. As a special option, the steel version can also be equipped with a pneumatic lifting function. The lifting function simplifies material pick-up and deposit.



Online configuration: [shop.strothmann.com](https://shop.strothmann.com)  
Learn more: [www.strothmann.com/en/leantrack](https://www.strothmann.com/en/leantrack)



# CustomTrack

## The customized transport system with individual carts

CustomTrack carts are fully adapted to your requirements thanks to a tailored cart and layout design. In particular the direction change systems increase the flexibility of the transport process. There are four different types of chassis available for the change of direction.

Cross-type chassis

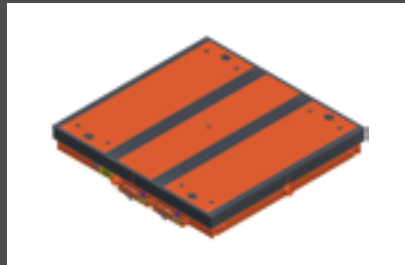

Quadro chassis



Flex chassis



Without chassis



### Customized transport carts

Let us develop the perfect cart for you: from consultation through design to production. The carts are customized for your processes and the transported products. Flexible factors include the cart design, load accommodation, track gauge and direction change technology. Various direction changing systems permit even complex travel paths.



Learn more: [www.strothmann.com/en/customtrack](http://www.strothmann.com/en/customtrack)



# PulseTrack

## The transport system for continuous flow production

PulseTrack is the simplest way to implement flow production. Connecting the pulse conveyor to the cart increases productivity thanks to fixed cycles and maximum energy efficiency.

### Line weight up to 600 tons

The PulseTrack system consists of a pulse conveyor and a cart of the series LeanTrack or CustomTrack. The carts are equipped with a carrier which is coupled to the drawbar of the cycle drive. The system permits ergonomic continuous flow production with a line weight of up to 600 tons. The products are automatically advanced to the next work station. Fixed cycles increase productivity.



### Minimized energy and follow-up costs

Maintenance-free components and higher energy efficiency make the PulseTrack extremely cost-effective and sustainable: One central drive for several cart permits simultaneous cycling of the entire line. This means the carts themselves have no drive.



### Simple control and maximum transparency

Each cycle drive is equipped with its own line control. The configurable dashboard enables maximum transparency and control.



Floor level

Completely closed system

Continuous or sequential

Min. installation space in the foundation

Learn more: [www.strothmann.com/en/pulsetrack](http://www.strothmann.com/en/pulsetrack)



# ServoTrack

## The powered transport system for straight routes

The powered transport cart for manual or fully automated processes is optimized for straight routes. ServoTrack is ideal for efficient material transport between two stations.

### Highly precise loading

The transport cart is ideal for highly precise and reliable transport of products with a weight of up to 200 t. The powered transport cart is ideal for linear routes, supply systems or highly precise loading of cells and stations. The chassis design is adaptable to the individual requirements. ServoTrack carts permit flexible integration of additional powered functions: Roller conveyors, rotating and reversing functions.



### Flexible control options

ServoTrack is available with different control concepts based on the application scenario. For instance, manual control is possible with a mobile manual control element or a control panel installed on the transport cart. In addition to partially automatic control, a fully automatic variant is also available. In this option, the higher-level control system or other systems can transmit the movement commands to the vehicle via cable or WIFI. The ServoTrack carts are equipped with state-of-the-art safety technology.



**100 %**

Flexible.  
Flexible chassis design

**100 %**

Modular.  
Integration of drive functions

**100 %**

Scalable.  
Pedestrian or fully automatic transport



## Maximum flexibility: through change of direction

Cross chassis in the cart or turning stations integrated in the floor allow the transport carts to change direction easily. This makes it possible to reach any position on the job site.

### Crossing elements (90°)

The cross chassis enables a change of direction in combination with crossing elements. The crossing element is installed together with the RoundTrack. Preferred use: few carts and many crossings. Preferred use: many crossings and few trolleys. Another advantage: the integrated lifting function can be easily extended to pick up and drop off transport tasks.

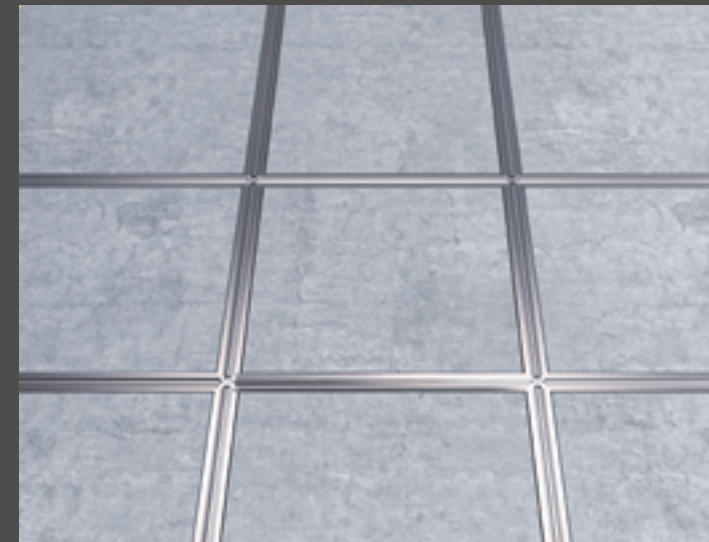

### Quadro turnstile, passive (90°)

The RoundTrack crossing consists of individual Quadro switches. The cassettes in the carriage are mounted on swivel bearings. In the case of a passive quadruple switch, the changeover is made by a manual switch lever or a swivel drive in the carriage.

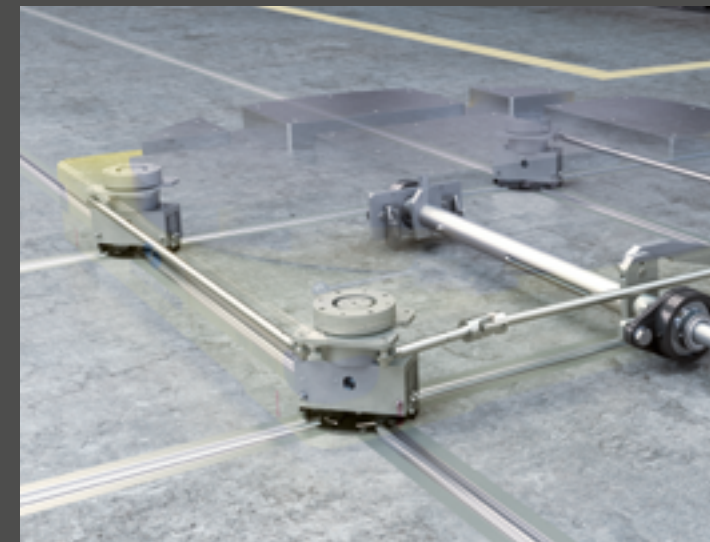
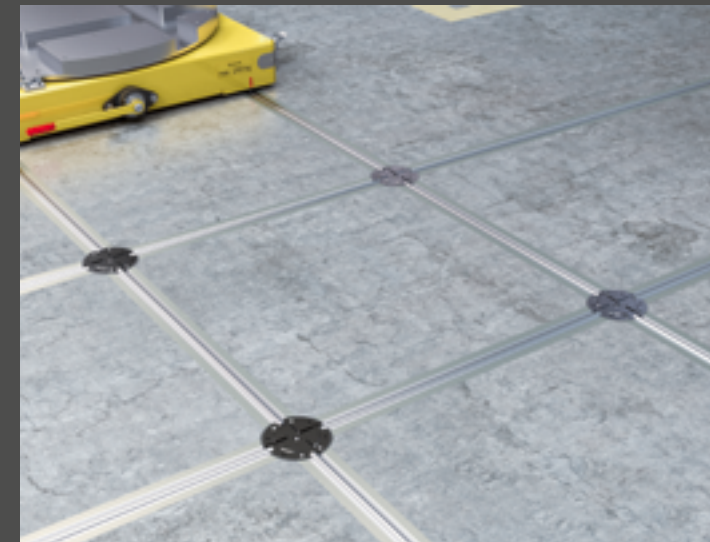

### Quadro turnstile, active (90°)

In the case of active quadruple points, the direction is changed by pneumatically driven quadruple points in the floor. Preferred use: many carriages with few crossovers, without inclines and without orientation changes. The advantage over the cross trolley: very low overall height of the trolley.

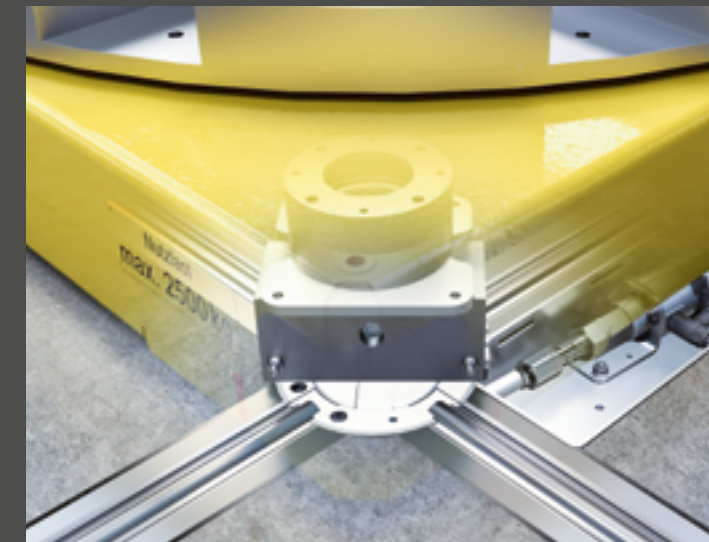
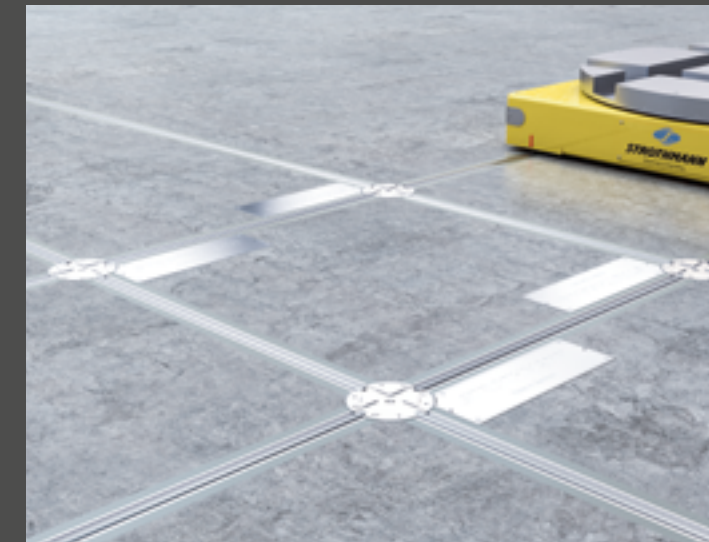

### Turning station (0 ... 360°)

The turning stations are manufactured individually according to the track width and cart size. The floor level turning stations can be turned manually or by an additional drive, as a result the orientation of the product is also changed. Preferred use: many carts, few crossings on inclined tracks or when changing orientation.

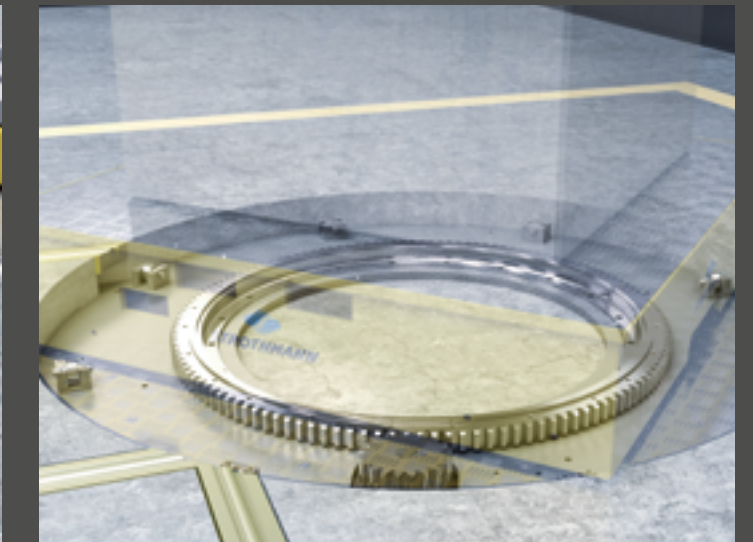



# System overview

## Transport systems

The wide range of available transport systems is designed for all common tasks in material handling and logistics. The systems permit flexible configuration and expansion: from direction changing to lifting functions.

	<b>LeanTrack</b> Standard carts	<b>CustomTrack</b> Customised carts	<b>PulseTrack</b> Pulse conveyor + carts	<b>ServoTrack</b> Driven carts	<b>UTrack</b> Transport carts
<b>Max. payload capacity*</b>	up to 72 t	up to 80 t	up to 600 t**	up to 200 t	up to 200 t
<b>Applications</b>					
Material handling	■	■		■	■
Machine loading	■	■		■	■
Continuous flow and cycled production	■	■	■		■
<b>Direction change</b>					
Cross-type chassis		■	■		■
Quadro turnstile		■	■		■
Turning station	■	■	■		■
<b>Energy supply</b>					
Battery				■	■
Induction				■	■
Cable drum				■	
<b>Mover</b>	■	■			
<b>Lifting functions</b>	■	■		■	■
<b>Rotating functions</b>		■		■	■
<b>High-precision chassis</b>		■	■	■	■
	Manual transport systems		Powered transport systems		Automated Guided Vehicles

\* Assumption: Load symmetrically distributed on 2 carts.  
 \*\* Line weight



# What kind of products would you like to transport with precision, reliability and low energy input?

Contact our RoundTrack experts:  
+49 5207 9122 265 | [sales@strothmann.com](mailto:sales@strothmann.com)

Learn more: [www.strothmann.com/roundtrack](http://www.strothmann.com/roundtrack)

## Headquarters

### STROTHMANN Machines & Handling GmbH

Altenkamp 11  
33758 Schloß Holte-Stukenbrock  
Germany  
Phone: +49 5207 9122 0  
E-mail: [info@strothmann.com](mailto:info@strothmann.com)

## Global presence

### Australia, New Zealand

Siempelkamp Pty. Ltd.  
+61 3 9596 7577  
[thiago.k@siempelkamp.com.au](mailto:thiago.k@siempelkamp.com.au)

### Czech Republic, Slovakia

Sales office Czech Republic and Slovakia  
+420 519 322 689  
[jjiri.bartos@teprostroj.com](mailto:jjiri.bartos@teprostroj.com)

### Mexico

In-Tech Automation  
+52 844 255 9194  
[ventas@intech-automation.mx](mailto:ventas@intech-automation.mx)

### USA

Strothmann Machines & Handling  
+1 312 982 2770  
[sales@strothmann.com](mailto:sales@strothmann.com)

### Brazil

Siempelkamp do Brasil Ltda.  
+55 41 3232 6806  
[frederico.marques@siempelkamp.com](mailto:frederico.marques@siempelkamp.com)

### Finland

ATP-trading Oy  
+358 9 341 77 514  
[petri.kuusisto@atp-trading.fi](mailto:petri.kuusisto@atp-trading.fi)

### Netherlands, Belgium

Wissekerke Techniek BV  
+31 187 490290  
[info@wissekerke.nl](mailto:info@wissekerke.nl)

### China

Strothmann Machines & Handling  
Trade (Shanghai) Co. Ltd.  
[shanghai@strothmann.com](mailto:shanghai@strothmann.com)

### France

Sales office France  
+33 608 755298  
[gerd.schaefer@orange.fr](mailto:gerd.schaefer@orange.fr)

### North America

Linear Automation Inc.  
+1 705 735 0000  
[sales@lineartransfer.com](mailto:sales@lineartransfer.com)

Information about the properties and application of products does not constitute a guarantee of properties, but is only intended for information purposes. The decisive factor for the scope of our delivery is the respective contract. RoundTrack® and uTrack® are registered trademarks by Strothmann Machines & Handling GmbH. Other designations used in this publication may be trademarks whose use by third parties for their own purposes could violate the rights of the owners.

© Strothmann Machines & Handling GmbH 12/2023



**STROTHMANN**  
Machines & Handling